



微信公众账号



FACEBOOK

安徽长庚光学科技有限公司

www.laowalens.com

服务热线:400-066-1316

Email: sales@laowalens.com

电话Tel:(+86) 0551-69107990

地址:合肥市庐阳区天水路与太和路交口庐阳中科大校友创新园5号楼

Add: Building 5, USTC Alumni Innovation Park, Crossing of Tianshui
and Taihe Road, Luyang District, Hefei City, Anhui Province, China

Mini FF II 85mm F5.6

Macro 2:1

使用手册

Instruction Manual

LAOWA 老蛙

本公司保留更改产品设计与规格的权利, 届时恕不另行通知;
本公司保留对此《使用说明》的最终解释权。

Please note we reserve the right to change our product's
design and specifications at any time without notice and
to the final interpretation of the *Instruction Manual*.



前言

真诚地感谢您选购 LAOWA (老蛙) Mini FF II 85mm F5.6 Macro 2:1 微距镜头。此镜头是全画幅系统镜头,支持微距模式下最大2倍放大,并且拥有接近于APO的色散控制能力。从无穷远到微距,都提供了极佳的成像画质,为用户提供了稳定可靠的支持。可拍摄到微小的物体,如小型昆虫、珠宝首饰等。



△ 为了操作上的安全,使用本产品前请务必仔细阅读使用手册与注意事项,并将手册放在需要时容易取得的地方。如遇到不能解决的问题请通过售后电话获取技术支持。

主要特色

- LAOWA老蛙 Mini FFII 85mm F5.6 Macro 2:1区别于传统的微距镜头,此款镜头在全画幅系统的高性能成像基础上,无穷远到微距都可以拍出高解析画质的照片,并且微距模式下达到了令人惊叹的2倍物体放大,接近于APO的色散控制,在2倍放大倍率下,也没有明显的色散。更高的放大倍率,使用户拥有更多的创作空间。
- 镜头采取迷你化设计,大小仅有 $\phi 53\text{mm} \times 78\text{mm}$,重量252g,搭配在无反全画幅机身上使用,体积小,轻便携带。
- 内部有3组13枚镜片,包含3枚异常分散玻璃结构带来的高素质成像。外有全金属材料制成的机械结构,保障了镜头长期使用的耐用性。

注意事项

△ 安全注意事项

- 切勿自行拆解、修改或改装。当产品由于外力原因破损,切勿触碰外露部分或破损边缘处。
- 切勿放置于直射阳光下、封闭车辆中或其余高温处,否则过高的温度会使镜片和其他部件产生伸缩变形。
- 不使用镜头时,请将镜头前盖盖上或置于没有阳光照射处。凸透镜反射出的光线可能会聚集在附近物体上,导致发生火灾。
- 在逆光拍摄时,切勿将太阳置于画面中心,应该使太阳充分偏离画角,否则阳光会在相机内部聚集并导致火灾或灼伤眼睛。
- 在使用相机内置闪光灯拍摄时,由于镜头本身会遮挡光线而产生渐晕,因此建议您使用外设闪光灯拍摄。

注意事项

■ 长期使用保养注意事项

- 避免触摸镜头表面,应用专用镜头布或气吹去除镜头表面的尘埃,不使用镜头时,应将镜头盖盖上。
- 使用镜头纸或镜头布清洁时,以螺旋的方式从中间向外擦拭镜头上的污垢以及指印。
- 镜头从寒冷的环境突然转移至温暖的环境时,镜头的外部以及内部镜片将会凝结水雾,所以在转移时应采取防潮保护措施。

各部件名称

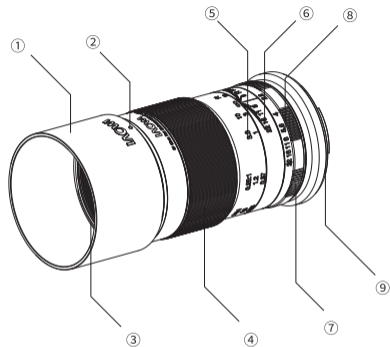

①遮光罩

②遮光罩安装标记

③滤镜(镜头盖)安装螺纹点

④对焦环

⑤距离(倍率)刻度

⑥景深指示刻度

⑦光圈环

⑧光圈刻度

⑨镜头安装标记

■ 镜头安装

- 取下镜头后盖。将镜头卡口上的安装标记⑨对准相机座圈上的对应标记, 随后将镜头插入机身座圈, 根据所购买卡口的安装方向旋转镜头, 直至咔嚓声锁紧镜头。安装时请不要用力过猛, 以免导致卡口损伤。

■ 镜头拆卸

- 关机后按住相机上的镜头释放按钮, 依照所购买卡口的安装方向反向旋转镜头, 随后将镜头从座圈中拔出。
- 装上镜头后, 请尝试旋转镜头确认是否已将其固定在相机上。

■ 遮光罩装卸

- 将遮光罩上的安装标记②对准镜头上的遮光罩安装点, 然后顺时针旋转遮光罩, 直至锁紧末端为止。
- 如要拆卸遮光罩, 按相反方向旋出即可。
- 安装遮光罩可减少强光并保护镜头前部元件。
- 安装某些滤光镜后, 您可能无法再使用遮光罩。
- 若不使用遮光罩时, 可将遮光罩反向安装于镜头上。
利用闪光灯拍摄时, 遮光罩可能遮挡住光线而造成影像上的渐量现象。所以在
- 使用相机闪光灯或使用高度不够的外置闪光灯时, 请拆卸遮光罩后再进行拍摄。或安装微距专用环形闪光灯。

■ 对焦

- 此款镜头是全手动对焦镜头, 合焦时, 缓慢旋转对焦环④, 直至合焦。
- 不要过猛过快地旋转对焦环, 避免用力过度损坏对焦环部件。
- 镜头上的距离刻度⑤与景深刻度⑥是出于指导目的。实际焦点与最深可能同刻度标记稍有不同。
- 如需要非常精确的对焦, 请在固定好相机位置的情况下使用最大光圈对焦, 对焦完成后再旋至所需要的光圈值。
- 为了对焦的方便性, 请开启相机内的峰值对焦功能(视所使用相机功能而定)。
- 此镜头有徕卡M卡口, 可实现黄斑联动, 但是由于黄斑联动的特性, 70cm内对焦, 尤其是微距拍摄, 需要通过屏幕进行对焦或者根据使用者的拍摄经验, 用取景器进行对焦。

■ 光圈使用

- 光圈在镜头上调节, 根据拍摄环境和与所需要的景深, 转动光圈环⑦ 来选择对应的光圈。
- 由于此镜头无CPU数据, 所以暂时无法记录光圈参数。
- 由于光圈为手动调节, 无法较好的使用快门优先模式, 但可以使用光圈优先模式(测光准确度视相机型号而定)。

■ 微距摄影模式

- 最大放大倍率为2: 1倍, 最近对焦距离为16.3cm, 从被拍物体镜头第一片玻璃的最近距离约9cm。

■ 对焦方法

对焦方法一：

放大倍率预先确定后再进行对焦

- ① 预先确定放大倍率，随后转动对焦环至所需的放大倍率刻度。
- ② 通过取景器或开启Live View (实时取景) 功能观察画面，并前后平移相机进行粗略对焦直至确定合适的焦距。
- ③ 转动对焦环对物体进行精确对焦。

对焦方法二：

先构定拍摄画面 在通过取景器或开启Live View (实时取景) 功能观察画面的同时，转动对焦环，构定拍摄画面后，进行方法一的②、③步骤。

- 在进行高放大倍率拍摄时，镜头的工作距离非常短，容易碰到拍摄物体，请小心拍摄。
- 放大倍率是指记录在传感器或胶片上的图像尺寸大小与拍摄物体的实际尺寸大小之间的比例关系。

LAOWA Mini FFII 85mmF5.6 Macro 2:1	
镜头型号	LAOWA Mini FFII 85mmF5.6 Macro 2:1
画幅	全画幅
焦点距离	85mm
光圈范围	F5.6-22
视场角	28.55°
镜头结构	9组13枚 (ED 镜片3枚)
光阑叶片	7片
最近摄影距离 (物像距离)	16.3cm
最大放大倍率	2倍
合焦驱动方式	手动 (MF)
滤镜尺寸	Φ46mm
镜头尺寸 (徕卡M)	约φ53mm*78mm
重量 (徕卡M)	约252g (不含遮光罩、前后盖)
卡口	徕卡M, 索尼E, 佳能R, 尼康Z

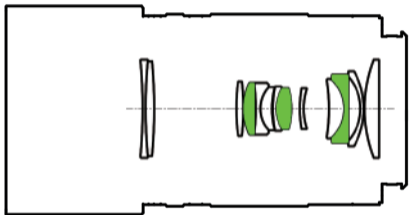

● 异常分散玻璃

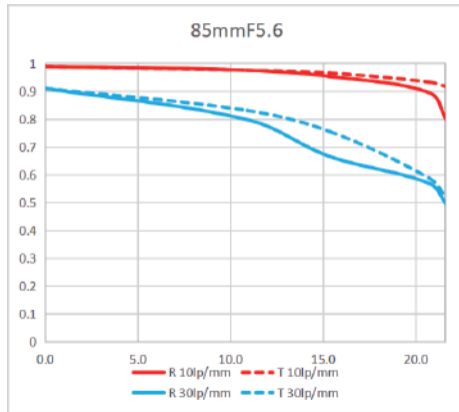

老蛙镜头

新创意·新乐趣





PREFACE

Thank you very much for purchasing LAOWA Mini FF II 85mm F5.6 Macro 2:1 lens. This lens is designed for full frame system. It supports max 2X macro magnification and has dispersion control ability close to APO . From infinity to macro, it provides excellent image quality and reliable support for users. It can capture very small objects , like insects and jewelry ,etc.



△ For safe operation, please read the manual and precautions carefully before you use the product, and place the manual where it is easy to obtain whenever required. If you have any unsolved problem please contact with our after-sales service team for further technical support.

FEATURES

- LAOWA Mini FF II 85mm F5.6 Macro 2:1 lens is distinct from traditional macro lenses, based on the high-performance image of the full frame system, this lens can take high-resolution pictures from infinity to macro, and the macro mode achieves an amazing 2x object magnification, which is close to the dispersion control of APO, and there is no obvious dispersion at 2x magnification. Higher magnification enables users to have more creative space.
- The lens adopts compact design, and the size is only ϕ 53mm*78mm, weighing 252g, which matches with full frame without reflector camera make it tiny size and portable.
- There are 3 groups of 13 lenses inside, including 3 special decentralized high-quality image glass structures. The surfacial mechanical structure made of 100% metal materials ensures the long-term durability of the lens.

PRECAUTIONS

Safety Precautions

- Do not disassemble, modify the lens by yourself. When the product is damaged due to external force, do not touch the exposed part or damaged edge.
- Do not leave the lens exposed to sunlight and closed vehicle or other high temperature places, otherwise excessive heat may deform the glass elements and other parts of the lens.
- When you do not use the lens, please cover front cap or leave it in a shade place, convex lens reflects light may be gathered on near objects and causes a fire.
- Do not place the sun in the frame center when shooting with backlight, you should make the sun deviates from the center to the corner, otherwise sunlight will be gathered in the camera and cause a fire or burn your eyes.
- The camera's built-in flash will cause vignetting because the lens shelters light. It is recommended you use external flash.

PRECAUTIONS

■ Long-term maintenance and precautions

- Do not touch the lens contacts. Clean by a lens cloth or a blower to remove the lens dirt. Always place the lens cap on the lens when storing.
- When you use lens paper or lens cloth to clean, remove the dirt and fingerprints on the lens from the middle to the outside in a spiral way.
- When the lens is suddenly transferred from a cold environment to a warm environment, the external and internal lenses will condense water mist, so moisture-proof protection measures should be taken during the transfer.

COMPONENT

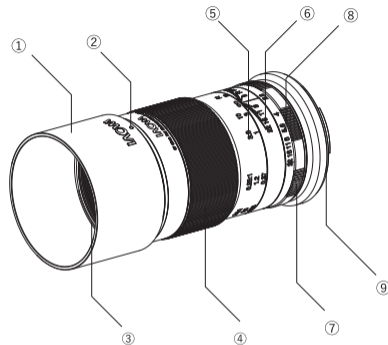

- ① Lens hood
- ② Lens hood mounting mark point
- ③ Filter (lens cap) mounting thread
- ④ Focus ring
- ⑤ Distance (magnification) scale

- ⑥ Depth of field scale
- ⑦ Aperture ring
- ⑧ Aperture scale
- ⑨ Lens mounting mark (on the bayonet)

INSTRUCTIONS

■ To install the Lens

- Remove the rear lens cap. Align the mounting mark⑨ on the lens bayonet with the mounting mark on the camera, then insert the lens into the camera seat ring and rotate it in the direction for your lens version until it locks. Do not use excessive force during installation to avoid damage to the bayonet.

■ To remove the lens

- Turn the camera off. While pressing the lens release button on the camera, rotate the lens in the opposite direction, then detach the lens from seat ring.
- After installation of the lens, please try to rotate the lens to make sure it mounted onto the camera properly.

INSTRUCTIONS

■ Installation/remove lens hood

- Align the mounting mark② on the lens hood with the lens. Turn the hood clockwise until it locks.
- For removing lens hood, rotate it counterclockwise.
- It is recommended that you use a lens hood to reduce strong light and protect the front elements.
- Lens hood may be unavailable when using certain filters.
- When storing, turn over the lens hood and place it onto the lens backward.
- When shooting with a flash, the lens hood may block light and cause vignetting. So when shooting with the camera's built-in flash or with the external flash unit that is not high enough, please remove the hood before shooting, or selecting an exclusive macro ring flash is also a great option.

INSTRUCTIONS

Focusing

- This is a fully manual lens. Rotate the focusing ring④ slowly to get focus.
- Turn the focus ring slowly and gently to prevent the focus mechanism from damage.
- The distance scale⑤ and depth of field scale⑥ are for instructional purposes. Actual focus and DOF may slightly differ from those scale indications.
- To get precise focus, it is recommended to focus through max aperture when the camera position is fixed. After finish focus , then set the desired aperture by rotating the aperture ring.
- For the focus convenience, please turn on peak focus function on the camera (Note that the function depends on camera models.)
- This lens has Leica M bayonet, which can realize rangefinder focus, but because of rangefinder focus within 70cm, especially take photo by marco distance, it needs get focus through the screen or according to users experience to get focus through finder.

INSTRUCTIONS

Setting the Aperture

- Aperture is set through the camera. According to the shooting situation and desired depth of field, rotate the aperture ring⑦ on the camera body to the corresponding aperture.
- Since the lens has no CPU data, the aperture value can not be recorded.
- Because aperture is adjusted manually, shutter priority function can not be used better, but aperture priority mode can be used (metering accuracy depends on the camera model).

Macro Shooting Mode

- The max magnification is 2:1 and the minimal focus distance is 16.3cm. The minimal distance from the object to the first of the lens is about 9cm.

INSTRUCTIONS

Focusing Tips

Method 1

Set the magnification first, then to get focus.

- ① Set the magnification first, and then turn the focus ring to the desired magnification scale on the lens.
- ② Check the frame by viewfinder or [Live View] on the camera and try to get focus by moving the camera back and forth until obtaining the proper focal length.
- ③ Rotate the focus ring to achieve precise focus.

Method 2

Set the frame first, then through viewfinder or Live View to check the image, at the same time to rotate focus ring. After constructing the shooting picture then make focus method 1 ②③ step.

- For high magnification shooting, extremely short working distance of the lens, it is very easy to touch the objects, please be careful.
- Magnification refers to the proportional relationship between the size of an image recorded on a sensor or film to the actual size of the object.

SPECIFICATIONS

LAOWA Mini FFII 85mm F5.6 Macro 2:1	
Lens No.	LAOWA Mini FFII 85mm F5.6 Macro 2:1
Frame	Full Frame
Focal Distance	85mm
Aperture Range	F5.6-22
Angle of View	28.55°
Lens Structure	Nine groups 13PCS(three ED glasses)
Diaphragm Blade	7PCS
Min. Shooting Distance	16.3cm
Max. Magnification	2X
In-focus Driving Mode	Manual(MF)
Filter Dimension	Φ46mm
Lens Dimension(Lecia M)	About φ53mm*78mm
Weight(Lecia M)	About 252g (exclude hood and front and back caps)
Mounts	Leica M, Sony E, Canon R, Nikon Z

LENS CONSTRUCTION

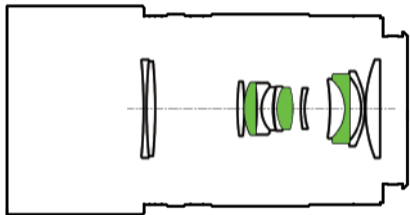

● Extra-low Dispersion Glass

MTF

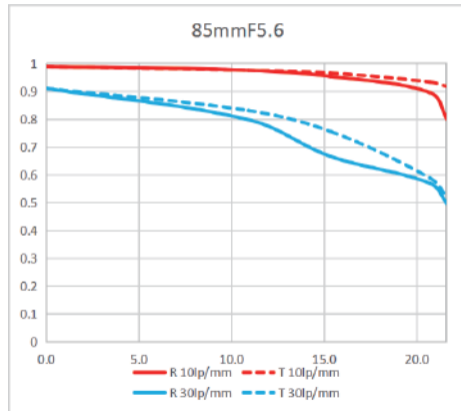

LAOWA

NEW IDEA . NEW FUN.