



微信公众账号



FACEBOOK

安徽长庚光学科技有限公司

[www.laowalens.com](http://www.laowalens.com)

服务热线:400-066-1316

Email: [sales@laowalens.com](mailto:sales@laowalens.com)

电话Tel:(+86) 551-69107990

地址:合肥市庐阳区天水路与太和路交口庐阳中科大校友创新园5号楼

Add: Building 5, USTC Alumni Innovation Park, Crossing of Tianshui  
and Taihe Road, Luyang District, Hefei City, Anhui Province, China

LAOWA GF 19mm F2.8 C&D-Dreamer

使用手册

Instruction Manual

**LAOWA** 老蛙

本公司保留更改产品设计与规格的权利, 届时恕不另行通知;  
本公司保留对此《使用说明》的最终解释权。

Please note we reserve the right to change our product's  
design and specifications at any time without notice and  
to the final interpretation of the *Instruction Manual*.



## 前言

真诚地感谢您选购LAOWA GF 19mm F2.8 C&D-Dreamer 中画幅系统超广角镜头。为了让您充分理解本产品的使用方法和注意事项,请您在使用前仔细阅读本说明书。



 为了操作上的安全,使用本产品前请务必仔细阅读使用手册与注意事项,并将手册放在需要时容易取得的地方。如遇到不能解决的问题请通过售后电话获取技术支持。

## 主要特色

- 1、LAOWA老蛙GF 19mm F2.8 C&D-Dreamer 为无反中画幅G卡口镜头,等效全画幅约15mm,视场角110°,让中画幅系统无需转接既能捕捉宽广的画面,增加了中画幅用户的更多超广角镜头选择。
- 2、老蛙镜头延续对于超广角镜头的极致要求,一如既往的采用近似零畸变的光学设计,采用10组12片光学镜片,内含2枚非球面镜以及3枚异常分散镜片,有效解决像差和畸变,为中画幅苛刻要求带来的更高标准的画质和体验。
- 3、F2.8最大光圈在中画幅系统中,属于大光圈镜头,可以在暗光环境下保持更低的感光度,保证画面纯净。适合星空题材摄影。
- 4、此镜头拥有全金属镜身设计,精度更高的同时也确保了耐用性,为中画幅用户带来更加坚实可靠的拍摄体验。
- 5、镜头前段采用非灯泡镜头设计,镜头自带圆形遮光罩,无需另配遮光罩。且镜头前端可装77mm口径的圆形滤镜,让摄影师体验更轻便的拍摄。

## 注意事项

### △ 安全注意事项

- 切勿自行拆解、修改或改装。当产品由于外力原因破损,切勿触碰外露部分或破损边缘处。
- 切勿放置于直射阳光下、封闭车辆中或其余高温处,否则过高的温度会使镜片和其他部件产生伸缩变形。
- 不使用镜头时,请将镜头前盖盖上或置于没有阳光照射处。凸透镜反射出的光线可能会聚集在附近物体上,导致发生火灾。
- 在逆光拍摄时,切勿将太阳置于画面中心,应该使太阳充分偏离画角,否则阳光会在相机内部聚集并导致火灾或灼伤眼睛。
- 在使用相机内置闪光灯拍摄时,由于镜头本身会遮挡光线而产生渐晕,因此建议您使用外设闪光灯拍摄。

## 注意事项

### 长期使用保养注意事项

- 避免触摸镜头表面,应用专用镜头布或气吹去除镜头表面的尘埃,不使用镜头时,应将镜头盖盖上。
- 使用镜头纸或镜头布清洁时,以螺旋的方式从中间向外擦拭镜头上的污垢以及指印。
- 镜头从寒冷的环境突然转移至温暖的环境时,镜头的外部以及内部镜片将会凝结水雾,所以在转移时应采取防潮保护措施。

## 各部件名称

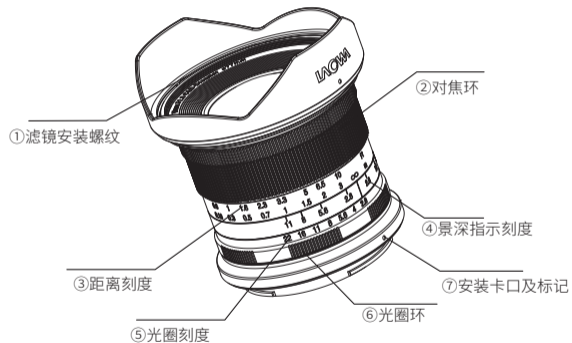

### ■ 镜头安装

取下镜头后盖。将镜头卡口上的安装标记⑦对准相机座圈上的对应标记，随后将镜头插入机身座圈，根据所购买卡口的安装方向旋转镜头，直至咔嚓声锁紧镜头。

### ■ 镜头拆卸

关机后按下相机上的镜头释放按钮，依照所购买卡口的安装方向反向旋转镜头，随后将镜头从座圈中拔出。

\*装上镜头后，请尝试旋转镜头确认是否已将其固定在相机上。

\*由于此为非CPU镜头，无法提供数据信息，所以请在相机内开启“无镜头释放快门”功能。

### ■ 对焦

- 此款镜头是全手动对焦镜头，合焦时，缓慢旋转对焦环②，直至合焦。  
\*不要过猛过快地旋转对焦环，避免用力过度损坏对焦环部件。  
\*镜头上的距离刻度③与景深刻度④是出于指导目的。实际焦点与景深可能同刻度标记稍有不同。  
\*如需要非常精确的对焦，请在固定好相机位置的情况下使用最大光圈对焦，对焦完成后再旋至所需要的光圈值。  
\*为了对焦的方便性，请开启相机内的峰值对焦功能(视所使用相机功能而定)。

### ■ 光圈使用

- 光圈在镜头上调节，根据拍摄环境和与所需要的景深，转动光圈环⑥来选择对应的光圈。  
\*由于此镜头无CPU数据，所以暂时无法记录光圈参数。  
\*由于光圈为手动调节，无法较好的使用快门优先模式，但可以使用光圈优先模式(测光准确度视相机型号而定)

规格表

LAOWA GF 19mm F2.8 C&D-Dreamer	
画幅	中画幅
焦点距离	19mm
光圈范围	F2.8-22
视场角	110°
镜头结构	10组12枚(2枚非球面, 3枚ED, 1枚超高折射率镜片)
光阑叶片	5片
最近摄影距离(物像距离)	18cm
最大放大倍率	0.185倍
合焦驱动方式	手动(MF)
滤镜尺寸	Φ77mm
镜头尺寸	Φ82.6mm*80mm
重量	约546g(不含前后盖)
卡口	富士G口

LAOWA 老蛙



## Preface

Thank you for choosing LAOWA GF 19 mm F2.8 C&D-Dreamer of ultra-wide-angle lens for medium-format system. In order for you to fully understand the usage of and precautions for this product, please read this manual carefully before use.



 *Read this operation manual carefully to familiarize yourself with its contents and ensure that you can operate the product properly. Keep the Instruction Manual in a safe place where it can easily be referenced whenever required. If you are still unable to solve the problem by reading the manual, please contact our after-sales service for further technical support.*

## Main features

- 1、LAOWA GF 19 mm F2.8 C&D-Dreamer is a mirrorless medium-format G-mount lens, with the equivalent full frame being about 15 mm and angle of field of view being 110°, which allows the medium-format system to capture a wide picture without switching, and add to the ultra-wide-angle lens options for medium-format users.
- 2、This LAOWA lens sticks to the extreme requirements for ultra-wide-angle lenses. As always, it adopts an optical design with almost zero distortion. In it, 10 groups and 12 pieces of optical lens pieces are used, including 2 non-spherical lenses and 3 anomalous dispersion lenses, which effectively solves aberrations and distortions. With all these, higher standards for picture quality and experience are brought about to meet the demanding requirements of medium-format.
- 3、A lens with the maximum aperture of F2.8 is a large aperture lens in the medium-format system, which can maintain a lower sensitivity in the dark environment to ensure the purity of the picture. It is suitable for starry sky theme photography.
- 4、This lens is designed with an all-metal lens body, which provides higher accuracy and also ensures durability, bringing a more solid and reliable shooting experience for medium-format users.
- 5、The front section of the lens adopts a non-bulb lens design, and the lens comes with a round hood, with which no other hood is needed to be equipped. And the front end of the lens can be equipped with a 77 mm circular filter, allowing photographers to experience more convenient shooting.

## Matters needing attention

### ■ △ Safety Precautions

- Do not disassemble, alter or modify the lens by yourself. When the lens is damaged due to external forces, do not touch the exposed part or the edge of the place of damage.
- Do not place the lens under direct sunlight, in a locked vehicle, or at other high-temperature places, or otherwise excessively high temperature will cause the lens and other parts to stretch and deform.
- When not using the lens, put the front lens cover the lens or place the lens at a place where there is no direct sunlight. The light reflected by the convex lens may collect on nearby objects and cause a fire.
- When shooting against the light, do not place the sun at the center of the frame, and sufficiently avoid the avoid from the angle of picture, or otherwise the sunlight will collect inside the camera and cause fire or burns to the eye.



## ■ Precautions for long-term use and maintenance

- Avoid touching the surface of the lens. Use special lens cloth or air blowing to remove dust on the surface of the lens. When the lens is not in use, put the cover it.
- When cleaning the lens with lens paper or lens cloth, wipe the dirt and fingerprints on the lens from the middle to the outside in a spiral manner.
- When the lens is suddenly transferred from a cold environment to a warm environment, water mist will be condensed on external and internal pieces of the lens, so moisture protection measures should be taken when the lens is being transferred.

## Nomenclature

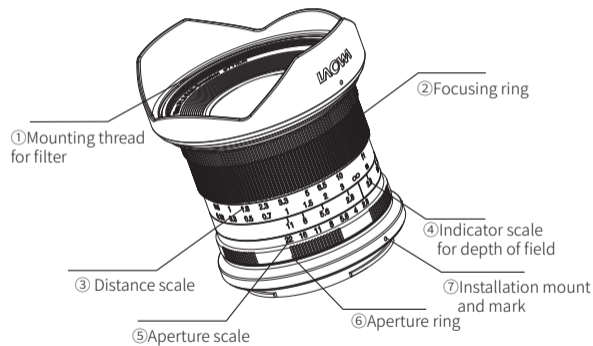

## Instructions for use

### ■ Lens installation

Remove the rear lens cap. Align the Mounting Mark ⑦ on the lens mount with the corresponding mark on the lens seat, then insert the lens into the seat on camera body, and turn the lens according to the mounting direction of the purchased mount until the lens is locked with a click.

### ■ Lens removal

After turning off the camera, press the lens release button on the camera, turn the lens in the direction opposite to the mounting direction of the purchased mount, and then pull the lens out of its seat.

\* After mounting the lens, please try rotating the lens to confirm whether it has been fixed on the camera.

\* For this is a non-CPU lens and digital information cannot be provided, please turn on the "release shutter without lens" function in the camera.

### ■ Focusing

This lens is a fully-manual-focus lens. When focus is achieved, slowly turn the Focusing Ring ② until focus is achieved.

\* Do not turn the focusing ring too fast or too hard to avoid damaging any focusing ring part with excessive force.

\* The Distance Scale ③ and Scale for Depth of Field ④ on the lens are for guidance purposes. The actual focus and depth of field may be slightly different from the scale marking.

\* If very precise focus is needed, please achieve focus using the maximum aperture with the camera position fixed, and then turn to the required aperture value after the focus is achieved.

\* For the convenience of focusing, please turn on the peaking focus function in the camera (depending on the camera function used).

## Focusing Methods

### ■ How to use the aperture

The aperture is adjusted on the lens. Turn the Aperture Ring ⑥ to select the corresponding aperture according to the shooting environment and the required depth of field.

\* As this lens is with no CPU data, it is temporarily impossible for the lens to record aperture parameters.

\* Since the aperture is adjusted manually, it is impossible for shutter priority mode to be put in relatively good use, but the aperture priority mode can be used (the metering accuracy depends on the camera model)

## Nomenclature

LAOWA GF 19 mm F2.8 C&D-Dreamer	
Format	medium format
Focal distance	19mm
Aperture range	F2.8-22
Angle of field of view	110°
Lens structure	<small>10 groups and 12 pieces (2 non-spherical pieces, 3 ED pieces, and 1 piece with an ultra-high refractive index)</small>
Aperture Blades	5pieces
Min. Shooting Distance	18cm
Max. Magnification	0.185times
Focusing	Manual (MF)
Filter Thread	Φ77mm
Dimensions	Φ82.6mm*80mm
Weight	About 546g (without lens hood and both front cap )
Mounts	Fuji G mount

