

LAOWA FFII Argus 28mm f/1.2

使用手册
Instruction Manual



微信公众账号 FACEBOOK

安徽长庚光学科技有限公司

www.laowalens.com

服务热线:400-066-1316

Email: sales@laowalens.com

电话Tel: (+86) 551-69107990

地址: 合肥市庐阳区天水路与太和路交叉口庐阳中科大校友创新园5号楼

Add: Building 5, USTC Alumni Innovation Park, Crossing of Tianshui
and Taihe Road, Luyang District, Hefei City, Anhui Province, China

LAOWA 老蛙

本公司保留更改产品设计与规格的权利, 届时恕不另行通知;
本公司保留对此《使用说明》的最终解释权。
Please note we reserve the right to change our product's
design and specifications at any time without notice and
to the final interpretation of the *Instruction Manual*.



前言

真诚地感谢您选购 LAOWA FFII Argus 28mm f/1.2 镜头。此镜头是针对全画幅系统大光圈镜头，最大光圈F1.2，采用内对焦设计，无级光圈，低呼吸效应，更倾向于视频拍摄。



为了操作上的安全，使用本产品前请务必仔细阅读使用手册与注意事项，并将手册放在需要时容易取得的地方。如遇到不能解决的问题请通过售后电话获取技术支持。

主要特色

- 1、Argus系列采用内对焦设计，内对焦是现代镜头主流设计结构，可以实现多组浮动匹配对焦，可矫正因距离变化产生的各种像差等，实现无限远和近距离均能优质成像。内对焦的设计，也能在恶劣环境下尽量避免进灰的情况。内对焦因长度不变，拍摄视频时不会干扰遮光斗，UV等配件，也不会干扰模特的注意力。内对焦通过组间间隔修正，实现了低呼吸效应，适合照片领域的同时，也比较适合视频创作。
- 2、镜头采取轻量化设计，大小仅有 $\phi 68.5 \times 106\text{mm}$ ，重量562g，搭配在全画幅机身上使用，体积小，轻便携带。
- 3、最大光圈F1.2，大光圈带来的浅景深的拍摄效果，更加突出拍摄主体，同时，在低照度的拍摄环境下，可以采用更低的感光度，让画面更加纯净。
- 4、镜头采用无级光圈设计，在视频拍摄过程切换光圈画面没有明显的明暗变化，光学设计优化了镜头的呼吸效应，较低的呼吸效应，焦点切换更加自然顺畅。
- 5、镜头由7组13片镜片组成，包含2枚异常分散玻璃、1枚非球面镜片和2枚特殊高折射玻璃的结构带来的高素质成像。外有全金属材料制成的机械结构，保障了镜头长期使用的耐用性。

注意事项

△ 安全注意事项

- 切勿自行拆解、修改或改装。当产品由于外力原因破损，切勿触碰外露部分或破损边缘处。
- 切勿放置于直射阳光下、封闭车辆中或其余高温处，否则过高的温度会使镜片和其他部件产生伸缩变形。
- 不使用镜头时，请将镜头前盖盖上或置于没有阳光照射处。凸透镜反射出的光线可能会聚集在附近物体上，导致发生火灾。
- 在逆光拍摄时，切勿将太阳置于画面中心，应该使太阳充分偏离画角，否则阳光会在相机内部聚集并导致火灾或灼伤眼睛。
- 在使用相机内置闪光灯拍摄时，由于镜头本身会遮挡光线而产生渐晕，因此建议您使用外设闪光灯拍摄。

注意事项

长期使用保养注意事项

- 避免触摸镜头表面,应用专用镜头布或气吹去除镜头表面的尘埃,不使用镜头时,应将镜头盖盖上。
- 使用镜头纸或镜头布清洁时,以螺旋的方式从中间向外擦拭镜头上的污垢以及指印。
- 镜头从寒冷的环境突然转移至温暖的环境时,镜头的外部以及内部镜片将会凝结水雾,所以在转移时应采取防潮保护措施。

各部件名称

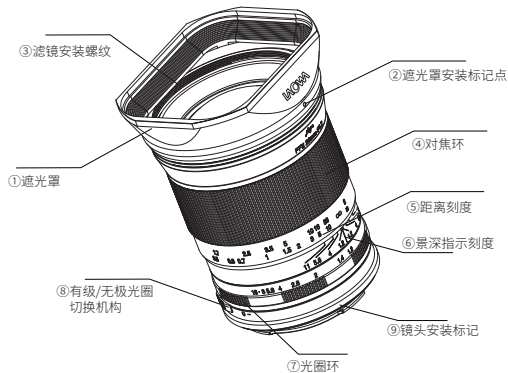

使用说明

■ 镜头安装

取下镜头后盖。将镜头卡口上的安装标记⑨对准相机座圈上的对应标记，随后将镜头插入机身座圈，根据所购买卡口的安装方向旋转镜头，直至咔嚓声锁紧镜头。安装时请不要用力过猛，以免导致卡口损伤。

■ 镜头拆卸

关机后按住相机上的镜头释放按钮，依照所购买卡口的安装方向反向旋转镜头，随后将镜头从座圈中拔出。

装上镜头后，请尝试旋转镜头确认是否已将其固定在相机上。

■ 遮光罩装卸

将遮光罩上的安装标记②对准镜头上的遮光罩安装点，然后顺时针旋转遮光罩，直至锁紧末端为止。
如要拆卸遮光罩，按相反方向旋出即可。

安装遮光罩可减少强光并保护镜头前部元件。

安装某些滤光镜后，您可能无法再使用遮光罩。

若不使用遮光罩时，可将遮光罩反向安装于镜头上。

利用闪光灯拍摄时，遮光罩可能遮挡住光线而造成影像上的渐量现象。所以在使用相机闪光灯或使用高度不够的外置闪光灯时，请拆卸遮光罩后再进行拍摄。

■ 对焦

此款镜头是全手动对焦镜头，合焦时，缓慢旋转对焦环④，直至合焦。

不要过猛过快地旋转对焦环，避免用力过度损坏对焦环部件。

不要过猛过快地旋转对焦环，避免用力过度损坏对焦环部件。

镜头上的距离刻度⑤与景深刻度⑥是出于指导目的。实际焦点与景深可能同刻度标记稍有不同。

如需要非常精确的对焦，请在固定好相机位置的情况下使用最大光圈对焦，对焦完成后再旋至所需要的光圈值。

为了对焦的方便性，请开启相机内的峰值对焦功能(视所使用相机功能而定)。

■ 光圈使用

光圈在镜身上调节,采用了无级光圈设计,光圈切换没有段落感,根据拍摄环境和与所需要的景深,转动镜身光圈环来选择对应的光圈,拍摄前建议检查光圈数值,以免误触改变拍摄参数。

由于此镜头无CPU数据,无法记录光圈参数。

■ 峰值对焦

- 1、开启机身峰值对焦选项,峰值颜色选择为红色或常用颜色,峰值选项为低。
- 2、通过取景器或开启Live View (实时取景)功能观察画面,通过峰值来观察对焦点。
- 3、转动对焦环对物体进行精确对焦。

■ 放大对焦

先构定拍摄画面,在通过取景器或开启Live View (实时取景)功能观察画面的同时,转动对焦环,构定拍摄画面后,通过按键或者双击屏幕将对焦点放大,转动对焦环直至合焦。

建议:由于F1.2光圈景深很浅,拍摄的过程中建议使用脚架和设置安全快门来保证画面稳定性。对焦建议使用峰值和放大相结合的对焦方式,保证焦点画面的锐利。

规格表

| LAOWA FF II Argus 28mm F1.2 | |
|-----------------------------|------------------------------|
| 画幅 | 全画幅 |
| 焦点距离 | 28mm |
| 光圈范围 | F1.2-16 |
| 视场角 | 75.4° |
| 镜头结构 | 7组13枚 (1枚非球面、2枚ED、2枚特殊高折射玻璃) |
| 光阑叶片 | 13片 |
| 最近摄影距离 (物像距离) | 50cm |
| 最大放大倍率 | 0.073 倍 |
| 合焦驱动方式 | 手动 (MF) |
| 滤镜尺寸 | Φ62mm |
| 镜头尺寸 | 约φ68.5mm*106.31mm |
| 重量 | 约562g (不含遮光罩、前后盖) |
| 卡口 | 索尼E、佳能R、尼康Z、马徕松L |



Preface

Thank you very much for purchasing LAOWA FF11 Argus 28mm f/1.2 lens. This is an ultra-fast f/1.2 lens for full frame systems which features an internal focusing design. This lens is suitable for shooting video with a de-clicked aperture ring and minimal focus breathing.



 *For operational safety, please read the manual and precautions carefully before using this product, and keep the manual at a place that is easily accessible when needed. If you encounter a problem that cannot be solved, please ask for technical support through email.*

Features

- 1.The Argus range features an internal focusing design, which is the mainstream photographic lens design of modern lenses. This lens employs multiple groups of floating matching focus. It works to correct any aberrations and to achieve corner to corner sharpness at all focal distances. The design of the internal focus can also be in the harsh environment to avoid as much as possible into the case of gray. The physical size of an internal focusing lens does not change during focus. It is useful for shooting videos as the model's attention and accessories like shading bucket and UV will not be interfered. The internal focusing design achieves a low breathing effect by inter-group interval correction, which is suitable for the photo shooting while also being more suitable for video shooting.
- 2.This lens is compact and portable adopting lightweight design, which can be used on full-frame cameras. It measures only 68.5mm in diameter, 106mm long and weighs 562g.
- 3.The maximum aperture of this lens is $f/1.2$. A fast aperture brings a shallow depth of field for more prominent shots of the subject, and at the same time, you can use a low ISO in low-light shooting environments for a purer picture.
- 4.The lens employs a de-clicked aperture design. Changing the aperture won't bring obvious changes in light during the video shooting. The optical design optimizes for a lower breathing effect and focuses switching becomes more natural and smooth.
- 5.The lens is constructed of 13 elements in 7 groups, including one aspherical element, two extra-low dispersion element and two high-refractive index elements. The all-metal structure ensures the lens' assembly accuracy and reliability.

Precautions

▲ Safety Precautions

- Do not disassemble, modify, or modify the product by yourself. When the product is damaged due to external force, do not touch the exposed part or the edge along the damaged part.
- Do not place the product in direct sunlight, in a closed vehicle, or other places with high temperature, or otherwise deformation in the form of expansion or contraction of the lens and other parts will occur under an excessive temperature.
- When the lens is not in use, please cover it with the front lens cap or place it at a place out of direct sunlight. Light reflected from a convex lens can collect on nearby objects, and cause a fire.
- When shooting in backlighting, do not place the sun in the center of the frame, and the sun shall be well off the angle of picture, or otherwise the sunlight will gather inside the camera and cause a fire or burn your eyes.
- When shooting is done with the built-in flash, vignetting will occur since the lens itself blocks the light, so shooting with an external flash is recommended.

Maintenance Precautions

- Do not touch the surface of the lens directly. Brush off any dust with a blower. Wipe the surface with a cleaning cloth or a lens tissue.
- Try a circular motion from the center outward to remove oil, fingerprints and grime on the lens surface.
- If your lens is brought directly from a cold place to a warm place, condensation may appear on the lens. To avoid this, be sure to take some action to protect the lens.

Name of each part

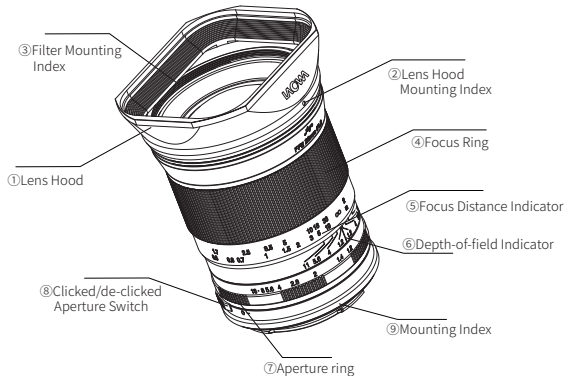

Instructions

■ To attach the Lens

Remove the rear lens cap. Align the mounting index⑨ on the lens bayonet with the mounting index on the camera, and place the lens on the camera mount, then rotate the lens according to the proper direction of the mount type until it locks. Do not use excessive force during installation to avoid damage to the bayonet.

After attaching the lens, please try to rotate the lens to make sure it mounted onto the camera properly.

■ To remove the lens

Turn the camera off. While pressing and holding the lens release button on the camera, rotate the lens in the reverse direction for attaching the lens until it stops, then detach the lens.

Instructions

■ Attaching/detaching lens hood

Align the mounting index on the lens hood② and the lens. Turn the hood clockwise until it locks.

For detaching lens hood, rotate it counterclockwise.

It is recommended that you use a lens hood to reduce strong light and protect the front element.

Lens hood may be unavailable when using certain filters.

When storing, turn over the lens hood and place it onto the lens backward.

When shooting with a flash, the lens hood may block light and cause vignetting. So when shooting with the camera's built-in flash or with the external flash unit that is not high enough, please remove the hood before shooting.

■ Focusing

This is a fully manual lens. Rotate the focusing ring④ slowly to get focus.

Turn the focus ring slowly and gently to prevent the focus mechanism from damage.

The distance scale⑤ and depth of field scale⑥ are for instructional purposes. Actual focus and DOF may slightly differ from those scale indications.

To get precise focus, it is recommended to focus wide open when the camera position is fixed. Get focus first, then set the desired aperture by turning the aperture ring.

Turn on the focus peaking on the camera to help focusing. (Note that the function depends on camera models.)

■ Setting the Aperture

Aperture is set through the aperture ring on the lens. The aperture is de-clicked. According to the shooting situation and desired depth of field, rotate the aperture ring on the lens to the corresponding aperture. It is recommended to check the aperture value before shooting to avoid unintended changing the value.

Since the lens has no CPU data, the aperture value can't be recorded.

■ Focusing Methods

Method 1 Focus Peaking

- ① Turn on the Focus Peaking on the camera. Chose the red color or other commonly used colors. Sets the Peaking Level to low.
- ② Check the frame by the viewfinder or [Live View] on the camera and try to get focus by Focus Peaking.
- ③ Rotate the focus ring to achieve precise focus.

■ Method 2

Focus Magnification

Set the frame first. Turn the focus ring while you are checking the image through the viewfinder or [Live View] on the camera. After setting the composition, magnify the focus by press the button on the camera or double click the screen, then turn the focus ring to get focus.

Note: Since the depth-of-field is very shallow at f/1.2, it is recommended to use a tripod and set the camera to the safe shutter speed to ensure picture stability during shooting. Focusing is recommended to use a combination of peaking and magnification to ensure a sharp image.

Specifications

| LAOWA FF II Argus 28mm F1.2 | |
|--|---|
| Format | Full Frame |
| Focal Distance | 28mm |
| Aperture Range | F1.2-16 |
| Angle of View | 75.4° |
| Lens Structure | 13 elements/7 groups (Aspherical Lens*1, ED glass*2, UHR glass*2) |
| Aperture Blades | 13 |
| Min. Shooting Distance (Object Image Distance) | 50cm |
| Max. Magnification | 0.073X |
| Focusing | MF |
| Filter Thread | Φ62mm |
| Dimensions | About φ68.5*106.31mm |
| Weight | About 562g (without lens hood and both front cap and rear cap) |
| Mounts | Sony E, Canon R, Nikon Z, L |